

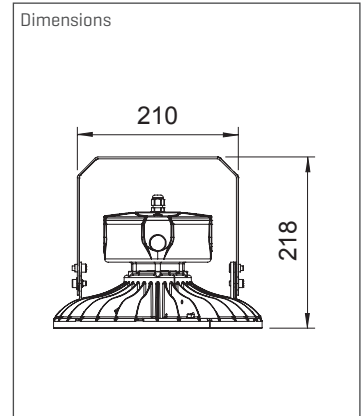

HBL | Area Light

HBL-150W

- Solid die-cast aluminum housing
- Perfect resistant coating
- Compact design, easy to handle
- Rotatable bracket made of stainless steel
- System efficacy up to 150 lm/W [Ra > 80]
- Emergency kit and motion sensor available



Product number	System performance typ. [W]	Light color	Beam characteristic	Luminous flux [lm]	CRI	Control
HBL-■K0-HP●-02◆▲C▷	120 / 150	WD=5000K WN=4000K	A2=120°, 60=60°, TA=60°x90°	18800-22700	8=CRI>80	D=dimnable

Article Number | Explanation

Example: HL-■S-HT●-02◆▲C▷

- HL Series
- System performance typ. [W]
- ◆ Light color
- ▲ Beam characteristic
- Control
- ▷ CRI
- * Dimensions [mm]
- × Equipment

For example: HL

HL Series, D=dimnable, 80/100 Watt, 5000K, A2=120°, 60=60°, TA=60°x90°, 8=CRI>80

TRS-STAR GmbH

Werner-von-Siemens-Str. 1
76297 Stutensee

Development, Planning
and Technical Sales
Dipl. Ing. Frank Werz
T +49 6233 347-125
werz@trs-star.com